

OPERATOR'S MANUAL

**MILLCREEK MODEL:
SPIN GROOMER with
OPTIONAL RAKE ATTACHMENT**
(sold separately)

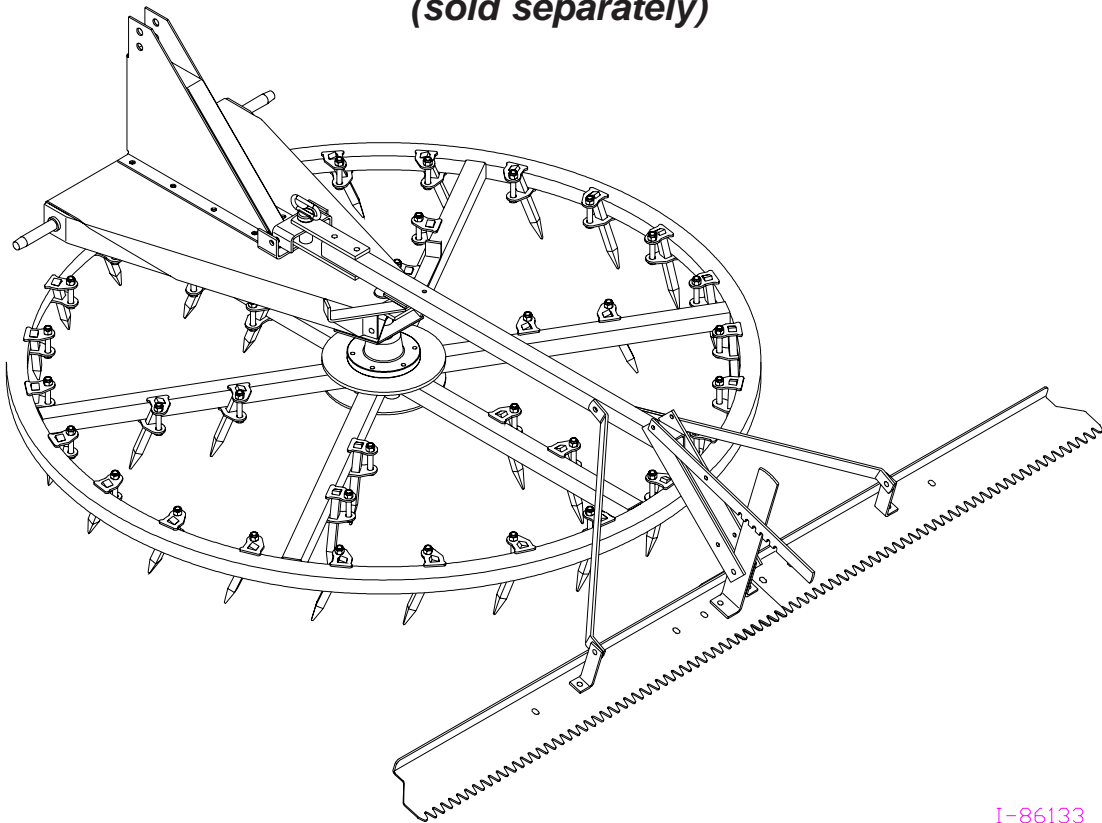

I-86133

PUBLICATION DATE: 4/11/05, Rev. 4

MILLCREEK PART # 43807

Millcreek Manufacturing Company
34 Zimmerman Road
Leola, PA 17540

Phone: 1-800-311-1323 / Fax: 717-656-0952
www.milkcreekspreaders.com



WARNING: DO NOT assemble, operate, or maintain this equipment without first reading and understanding the information provided in this manual. Failure to follow all safety precautions as stated in the manual may result in serious personal injury or death.

WARRANTY INFORMATION

Millcreek Manufacturing Company (hereinafter called the Company) warrants to the original Purchaser, the Equipment, manufactured by the Company, to be free from defects in material and workmanship under normal use and service. The Company obligation under this Warranty shall be limited to replacement or repair of any parts thereof, free of charge, to the original Purchaser, at their place of business, provided, however, that the part(s) to be replaced or repaired, shall, within one year after delivery to the original Purchaser, be demonstrated to be defective; which determination shall be made by the Company. The said components or parts must be returned through the Selling Dealer or Distributor directly to the Company with all transportation charges prepaid. Notice of defect shall be furnished in writing to the Seller and to the agent through whom the machinery was purchased, disclosing in full all known defects and failure in operation and use. Reasonable time shall be given to the Seller to remedy any such defects and failures.

This Warranty does not cover, under any circumstances, any parts, components, or materials which, in the opinion of the Seller and the Company, have been subjected to neglect, misuse, alteration, accident, or repaired with parts other than those manufactured by and obtained from Millcreek Manufacturing Company.

This Warranty does not cover components which are already covered by a separate warranty provided by the supplier of said parts or components.

This Warranty is made in lieu of all other warranties, expressed or implied, including any warranty of merchantability and fitness for use and purpose and of all other obligations or liabilities on the Company part and any implied warranty. The Company neither assumes nor authorizes any other person to assume for it, any other liability in connection with the sale of this equipment. This Warranty shall not apply to this equipment or to any part thereof which has been subjected to accident, negligence, alteration, abuse, or misuse.

The Company makes no warranty whatsoever in respect to accessories or parts not supplied by the Company. The term "original Purchaser," as used in this Warranty, shall be deemed to mean that person for whom the equipment is originally supplied. This Warranty shall apply only within the boundaries of the continental United States.

Under this Warranty, the Company cannot guarantee that conditions existing beyond its control will not affect the Company's ability to obtain materials or manufacture necessary replacement parts.

The Company reserves the right to make design changes, or changes in specifications at any time, without any contingent obligation on the part of the Company to purchasers of machines and parts previously sold.

The Company warrants the construction of the equipment sold herein and will replace at the Company's expense for a period of one year from the date hereof, any parts which prove defective as determined under the terms of this Limited Warranty.

TRADEMARKS

The Millcreek logo is a trademark of the Millcreek Manufacturing Company. All other brand or product names mentioned are the registered trademarks or trademarks of their respective owners.

COPYRIGHT

Copyright © 2005 Millcreek Manufacturing Company. All rights reserved. No part of this publication may be reproduced, or distributed without the prior written permission of Millcreek Manufacturing Company, 34 Zimmerman Road, Leola, PA 17540. Subject to change without notice.



TABLE OF CONTENTS

SECTION 1: INTRODUCTION	1-1
Guide to this Manual	1-1
For Your Safety... ..	1-1
Safety Labels	1-3
SECTION 2: UNPACKING & ASSEMBLY	2-1
Removing the Shipping Crate	2-1
Warranty Registration	2-1
Attaching the 3-Point Mast to the Spin Groomer Hitch	2-2
Assembling the Spin Groomer Hitch to the Grooming Ring	2-2
Assembling the Rake	2-3
Attaching the Rake to the Spin Groomer	2-4
Connecting the Spin Groomer Hitch to the Tractor	2-5
Connecting the Rake Attachment to the Tractor	2-5
SECTION 3: OPERATION	3-1
Understanding Spin Groomer and Rake Attachment Operation	3-1
How the Spin Groomer Works	3-1
How the Rake Attachment Works	3-1
Operating the Spin Groomer	3-2
Adjusting the Spin Groomer for Operation	3-2
Operating the Spin Groomer	3-3
Fine Tuning Spin Groomer Penetration	3-3
Operating the Rake Attachment	3-3
SECTION 4: MAINTENANCE	4-1
Guidelines for Regular Maintenance	4-1
Spin Groomer Maintenance	4-1
APPENDIX A: PARTS REFERENCE	A-1
General Spin Groomer Specifications	A-1
Ordering Information	A-1
Spin Groomer Component Parts Detail	A-2
Rake Attachment Component Parts Detail	A-4

SECTION 1: INTRODUCTION

Guide to this Manual

This manual contains all the information necessary to safely assemble and operate the Millcreek Spin Groomer and Optional Rake Attachment. Consult the Table of Contents for a detailed list of topics covered. You'll find this manual's step-by-step procedures easy to follow and understand. Should questions arise, please contact your Millcreek dealer before starting any of the procedures in this manual.

NOTE: The Spin Groomer and Rake Attachment may be used together or separately. You may have received one or both components depending upon your order. This manual provides all necessary procedures for assembly and operation of each component. Please refer to the Table of Contents to locate the applicable procedures for your equipment.

Regarding the information presented in this manual:

- All safety, operating, and servicing information reflects current production models at the time of publication of this manual.
- References made to left, right, front, and rear are those directions viewed when facing the unit from the rear.

Please read all sections in the manual carefully--including the important safety information found in this section--before beginning any assembly/operation procedures; doing so ensures your safety and the optimal performance of your Millcreek Spin Groomer and Rake Attachment.

For Your Safety...

For your safety, Millcreek documentation contains the following types of safety statements (listed here in order of increasing intensity):

- **NOTE:** A clarification of previous information or additional pertinent information.
- **ATTENTION:** A safety statement indicating that potential equipment damage may occur if instructions are not followed.



CAUTION: A safety statement that reminds of safety practices or directs attention to unsafe practices which could result in personal injury if proper precautions are not taken.



WARNING: A *strong* safety statement indicating that a hazard exists which can result in injury or death if proper precautions are not taken.



DANGER! *The utmost levels of safety must be observed;* an extreme hazard exists which would result in high probability of death or irreparable serious personal injury if proper precautions are not taken.

The best operator is a careful operator. By using common sense, observing general safety rules, and adhering to the precautions specific to the spin groomer and rake attachment, you, the operator, can promote safe equipment operation.

For Your Safety... (continued)

In addition to observing the specific precautions listed throughout the manual, **the following general precautions apply and *must be heeded* for proper, safe operation.**

 **WARNING:** To prevent serious personal injury, keep hands and feet from under equipment at all times. Ensure that you are safely distanced from any other persons before operating the spin groomer and/or rake attachment.

 **WARNING:** DO NOT attempt to operate the equipment in areas with steep inclines, ditches, large rocks, stumps, or holes which may endanger the operator by upsetting the tractor or cause damage to the equipment.

 **WARNING:** To prevent injury and to promote safe spin groomer operation, DO NOT exceed the maximum operating speed of 8 mph. Recommended tractor ground speed is 3 to 5 mph.

 **WARNING:** To prevent serious personal injury, never repair the spin groomer while the tractor is moving or while the three-point hitch is holding the unit off the ground.

 **WARNING:** To prevent injury and to ensure optimal operation of the equipment, ensure that all mounting hardware is properly tightened before operating the spin groomer and/or rake attachment.

 **WARNING:** Never get off the tractor while it is in motion and/or the spin groomer is in operation (same applies for the rake attachment).

 **WARNING:** Never allow children or anyone else to ride on the tractor or spin groomer/rake attachment.

 **CAUTION:** When transporting the rake attachment with a tractor (and the rake is not to be in operation), be sure to install the safety latch pin to prevent the rake from moving sideways. Failure to do so may result in personal injury and/or property/equipment damage.

 **CAUTION:** When operating the rake attachment with a tractor (i.e. by itself, not with the spin groomer), be careful to make wide sweeping turns. Turning too sharply may cause the rake to swing erratically and suddenly, which may result in property/equipment damage and/or personal injury.

ATTENTION: For proper and safe operation of the equipment, periodically inspect all parts for excessive wear. Replace worn components with factory-authorized parts.

Safety Labels

The following safety decals have been placed on your spin groomer and rake attachment to remind you of critical safety precautions which must be heeded for the personal safety of you, the operator, and any persons in the vicinity of the equipment while it is in operation. Be sure to keep the safety decals clean and readable. If the decals ever become damaged or illegible, contact your Millcreek dealer for free replacements.



NOTE: This safety label, **Millcreek Part Number 42812**, is located on the spin groomer hitch mast, just above the Millcreek logo, and on top of the rake attachment. The safety messages contained in the **WARNING** label apply to **BOTH** the spin groomer and the rake attachment, whether used together or separately.

SECTION 2: UNPACKING & ASSEMBLY

Before assembling your spin groomer and/or rake attachment, you must carefully unpack the equipment from the shipping crate and inspect the shipment. Be sure to complete the warranty registration card(s) following unpacking and inspection.

Assembly of the equipment is outlined in the following procedures (*please refer to those that apply to the equipment you ordered*):

- Assembling the 3-Point Mast to the Spin Groomer Hitch
- Assembling the Spin Groomer Hitch to the Grooming Ring
- Assembling the Rake
- Attaching the Rake to the Spin Groomer
- Connecting the Spin Groomer Hitch to the Tractor
- Connecting the Rake Attachment to the Tractor

Detailed parts drawings are provided in the Appendix at the back of this manual (for reference as needed).

Removing the Shipping Crate and Inspecting All Components

1. Carefully remove the top boards of the spin groomer shipping crate.
 2. With the assistance of another person(s), carefully lift the spin groomer components out of the shipping crate. Each spin groomer shipment includes: the three-point spin groomer hitch, the grooming ring, a hardware bag, and product documentation (manual, warranty card, etc.)
NOTE: Approximate weight of the grooming ring ranges from 160 lbs. for the 5 ft. ring up to 230 lbs. for the 7 ft. ring.
 3. If you ordered a rake attachment, it is shipped separately in two boxes. One box contains the two rake pieces. The other box contains the arm assembly components, mounting bracket, side stop, and hardware for assembly of the rake attachment.
 4. Inspect the spin groomer and/or rake attachment components to ensure that they have been shipped to you in a satisfactory manner.
NOTE: Immediately notify the freight company and your Millcreek dealer in case of shipping damage, shortage(s), and/or errors.
 5. Locate all safety decals and review their content.
-

Warranty Registration

For proper warranty registration, Millcreek requires that you fill out the provided warranty registration card and return it *within 30 days* to:

MILLCREEK WARRANTY REGISTRATION
Millcreek Manufacturing Company
34 Zimmerman Road
Leola, PA 17540

Assembling the 3-Point Mast to the Spin Groomer Hitch

1. Refer to Figure 2A.
2. Position the 3-point mast vertically over the hitch, being sure to properly align the holes for installation of the bolts.
3. Use the 1/2 x 1" bolts, lock washers, and nuts (8 supplied, 4 for each side of the mast) to fasten the mast to the hitch.
4. Ensure that all hardware is firmly tightened.

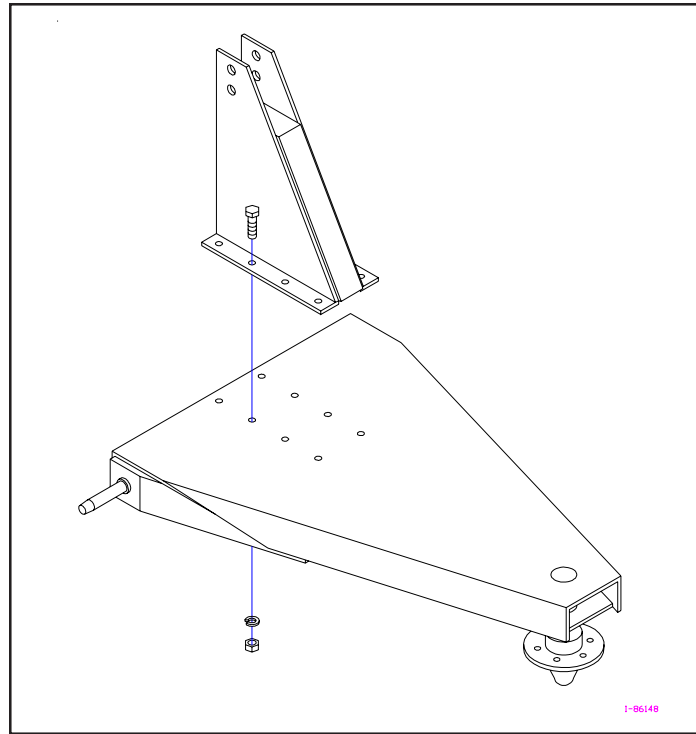

Figure 2A - Attaching the Mast to the Hitch

Assembling the Spin Groomer Hitch to the Grooming Ring

1. Set the grooming ring securely on 8" high blocks.
2. Set the spin groomer hitch on top of the grooming ring, being sure to properly guide the hub of the hitch through the center hole in the ring.
3. Install the six (6) bolts which attach the grooming ring to the hub on the hitch. Note that the bolts must be threaded from the bottom of the ring up through the access hole and into the hub using a socket and ratchet extension (as shown in Figure 2B).

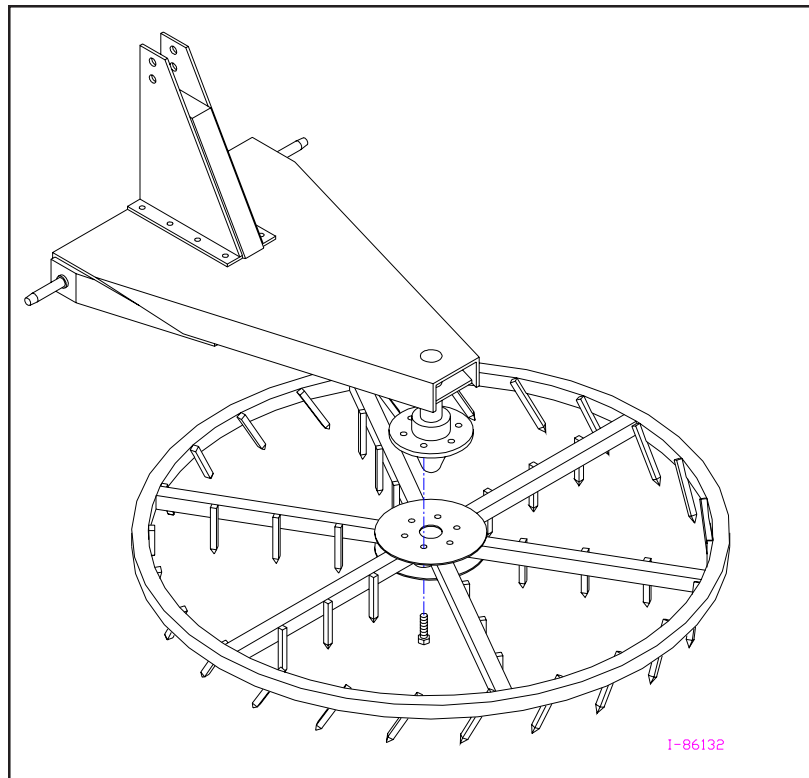

Figure 2B - Assembling the Grooming Ring and Hitch

Assembling the Rake

1. Refer to the **Rake Attachment Parts Detail** drawing in Appendix A at the back of this manual.
2. Assemble the two hitch braces to the rake attachment arm assembly using the hardware supplied (1/2 x 3" bolts, 1/2" lock washers and nuts).
3. Refer to Figure 2C and determine the appropriate assembly for your rake pieces. Note that the two rake pieces may be assembled for different lengths according to the size of spin groomer being used. If you are using the rake attachment by itself (i.e. without a spin groomer), choose the size that is most appropriate for your grooming application.
4. Assemble the rake pieces to the hitch braces as shown, using the hardware supplied (1/2 x 1-1/2" bolts, 1/2" lock washers and nuts).

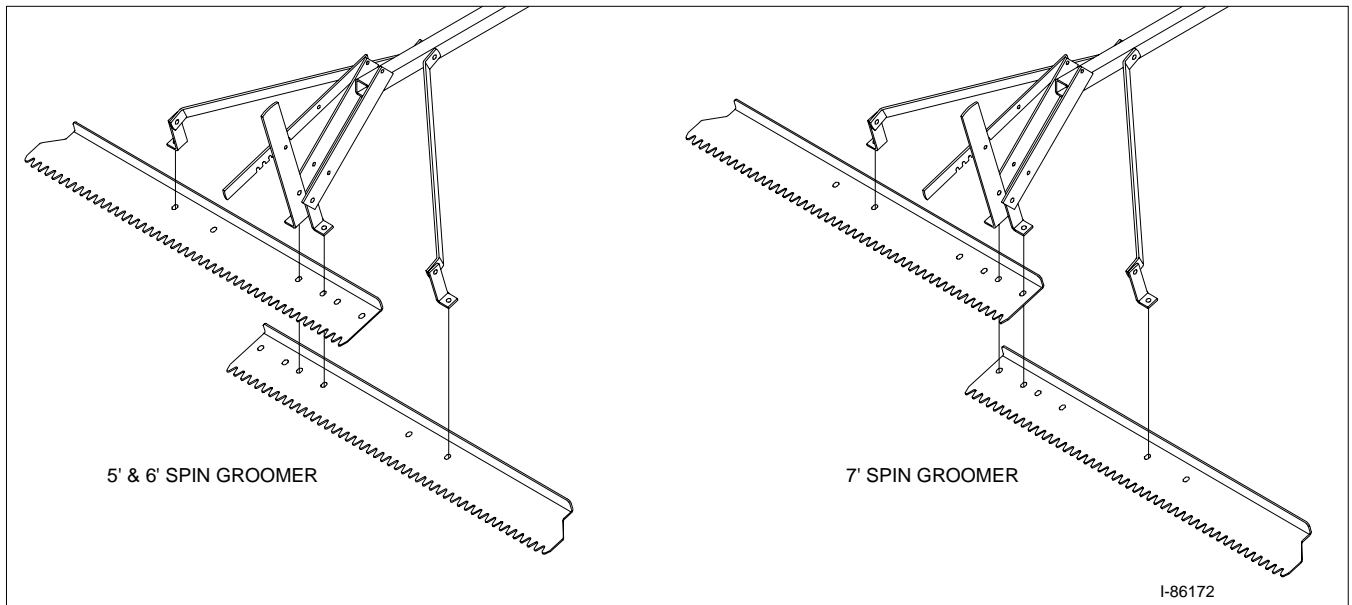

Figure 2C - Assembling the Rake

Attaching the Rake to the Spin Groomer

NOTE: Field drilling of mounting holes as outlined in steps 2 and 5 in the following procedure is required **ONLY** for older model spin groomers. Current model spin groomers are supplied from the factory with the mounting holes pre-drilled.

1. Position the rake attachment side stop bracket on top of the spin groomer hitch as indicated in Figure 2D. Align the key on the side stop bracket with the back edge of the hitch. Ensure that the side stop bracket is centered for proper installation.
2. **For Field Drilling ONLY:** Mark two holes for drilling (one on either side) of the spin groomer hitch as shown in Figure 2D. Wearing safety glasses, drill the holes using a 1/2" bit.
3. Mount the side stop to the spin groomer hitch using the 1/2 x 1-1/4" bolts, lock washers, and nuts as indicated in the **Rake Attachment Parts Detail** drawing provided in Appendix A at the back of this manual.
NOTE: 1/2" flat washers (2) are supplied for use as shims, if needed.
4. Position the rake attachment arm assembly over top of the spin groomer. Install the bent pin (safety latch pin) into the first hole in the arm assembly and slide down through the hole in the side stop bracket as indicated in Figure 2D. Doing so centers and holds the rake in its safety position (i.e. for transportation).
5. **For Field Drilling ONLY:** Using the holes in the rake mounting bracket as a guide, mark the final two holes for drilling as indicated in Figure 2D, just in front of the spin groomer mast. Wearing safety glasses, drill the holes using a 1/2" bit.
6. Fasten the rake mounting bracket to the top of the spin groomer hitch using 1/2 x 1-1/4" bolts, lock washers, and nuts as shown in the **Rake Attachment Parts Detail** drawing.

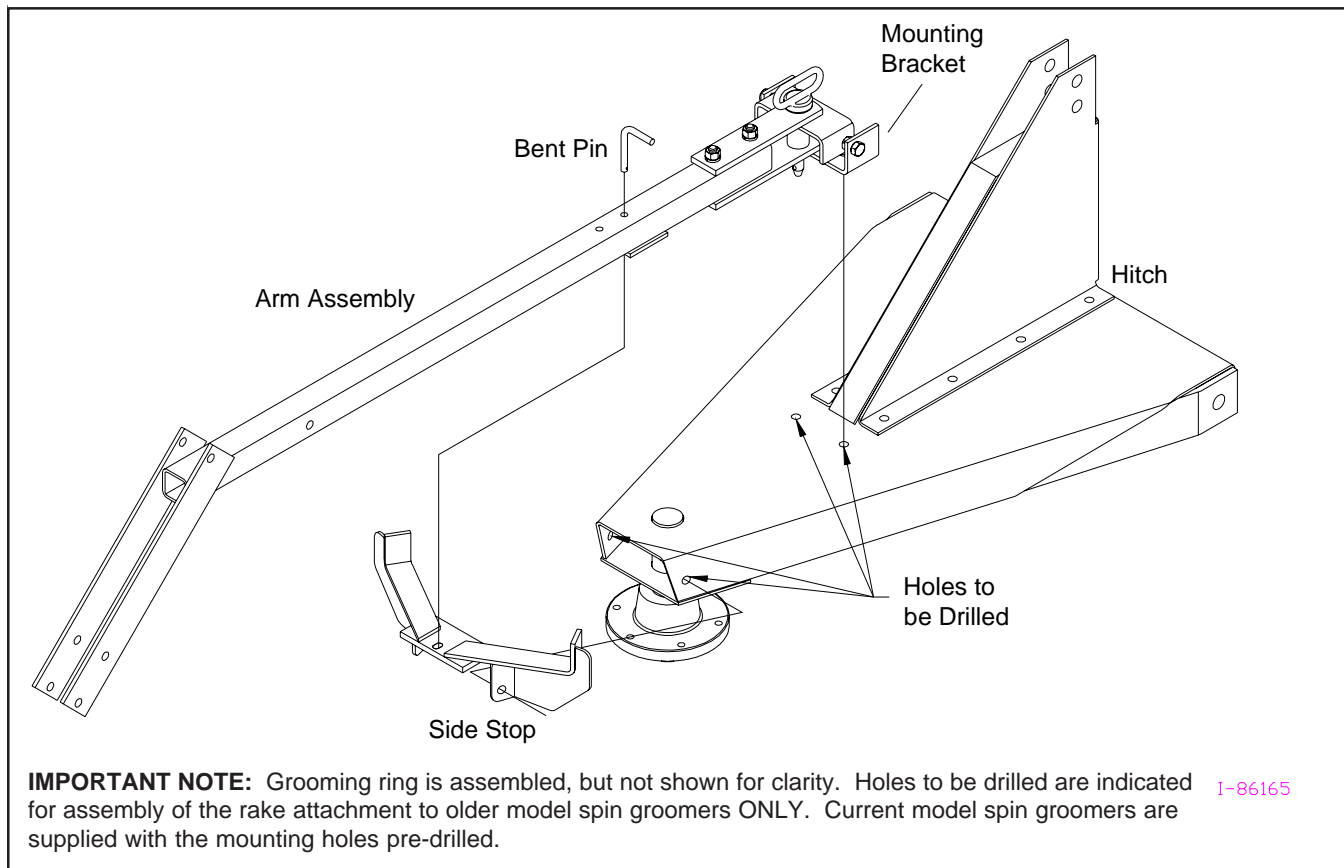

Figure 2D - Attaching the Rake to the Spin Groomer

Connecting the Spin Groomer Hitch to the Tractor

The spin groomer is designed to work with any tractor that uses a standard three-point lift, category "1" hitch.

1. Following assembly of the spin groomer hitch and ring, remove the blocks and set the spin groomer on the ground.
2. Back the tractor into the spin groomer three-point hitch. Ensure that both lower three-point lift arms on the tractor are level (i.e. same distance from the ground).
3. Connect the two lower arms on the tractor hitch to the two hitch pins on the spin groomer.
4. Adjust the upper three-point arm in or out until the arm on the tractor matches the top hole on the spin groomer hitch.
5. Install lynch retaining pins to hold the spin groomer in place.



CAUTION: To prevent personal injury, ensure that all lynch retaining pins are securely installed before attempting to lift the spin groomer.

Connecting the Rake Attachment to the Tractor

NOTE: This procedure applies for grooming applications where the rake is to be connected directly to the tractor (i.e. by itself, without the spin groomer).

1. Pull the rake attachment into position behind the tractor.
2. Align the holes in the rake mounting bracket with the tractor hitch, and install the hitch pin (supplied with the rake attachment).

SECTION 3: OPERATION

Understanding Spin Groomer and Rake Attachment Operation

Proper and safe operation of the Millcreek spin groomer and rake attachment requires: (1) being familiar with the method of operation and (2) heeding all safety precautions as stated in this manual.

How the Spin Groomer Works

As the tractor moves forward, the spin groomer begins to rotate. As proper speed is achieved, the teeth on the grooming ring "dig into" the ground surface and loosen the dirt. The grooming action of the spin groomer is directly related to the depth at which the grooming ring digs into the ground surface. This surface penetration is dependent upon the condition of the dirt surface (i.e. hard-packed, granular, wet, dry, etc) **and** the angle or pitch of the ring.

Control and adjustment of the grooming ring is achieved by (1) lengthening or shortening the top lift arm on the three-point hitch and (2) raising or lowering the lower righthand linkage. *Note that when you mounted the spin groomer on the tractor hitch, the two lower linkages on the tractor were level.*

How the Rake Attachment Works

The addition of a rake attachment with a spin groomer achieves even finer grooming for horse tracks, ball fields, or landscaping applications. Attaching the rake directly to the tractor provides quick and easy grooming capabilities.

The rake is designed so that it can be assembled in several different lengths to match the spin groomer size or desired grooming application width.

The operating angle of the rake is easily adjusted with a spring-loaded lever at the base of the rake arm assembly.

Operating the Spin Groomer

Before proceeding with operation of the spin groomer, review all safety statements as provided in Section 1 of this manual.



CAUTION: To prevent injury, ensure that all people and animals stay clear of the hitch arms and grooming ring during adjustment and operation.

ATTENTION: In order to obtain proper, aggressive spinning action, *the recommended tractor ground speed is 3 to 5 miles per hour. To maintain safe operation, DO NOT exceed 8 miles per hour.*

Adjusting the Spin Groomer for Initial Operation

1. Start the tractor, and move to level ground. After parking the tractor, be sure to lock the wheels.
2. Raise the spin groomer with the tractor three-point hitch so that the front part of the grooming ring is approximately two inches off the ground. (**Refer to Figure 3A**; the front part of the grooming ring is that portion at the "12 o'clock" position.)
3. Turn the tractor engine off.
4. Level the rear part of the grooming ring (front to back) by lengthening or shortening the top lift arm of the three-point hitch.
5. For initial operation, adjust the angle of the spin groomer by *shortening the lower righthand linkage*; this adjustment tilts the grooming ring. Continue to shorten the right lower linkage until the teeth of the grooming ring on the lefthand side ("9 o'clock" position) are approximately 1-1/2 inches lower than the righthand side ("3 o'clock" position).
6. Now *lengthen the top lift arm* of the tractor three-point hitch so that the **lowest point of the grooming ring is at "8 o'clock"** as shown in Figure 3A. ***This is the recommended point of greatest penetration.***
7. Re-start the tractor, and unlock the wheels. Raise the spin groomer to a safe traveling height, and move to the area on which you wish to begin the grooming operation.

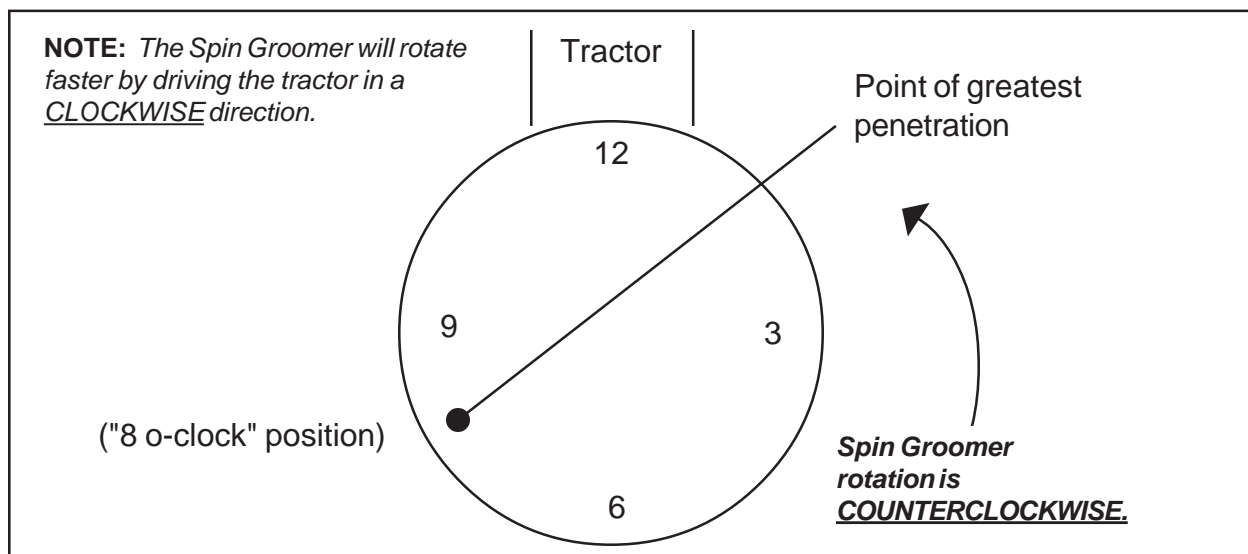

Figure 3A - Adjusting for Point of Greatest Penetration

Operating the Spin Groomer

1. If using the spin groomer with the rake attachment, move the bent pin on the rake arm to the holding position (next hole adjacent to the safety position).
2. Slowly lower the spin groomer until the grooming ring rests on the ground in the "8 o'clock" position (refer to Figure 3A). As the tractor moves forward and achieves the recommended operating speed (not to exceed 8 mph), the spin groomer will rotate *counterclockwise* and begin loosening and grooming the surface.
NOTE: The adjustments made in the previous procedure have set the spin groomer to spin *counterclockwise* during operation; the tractor should then travel in a *clockwise* direction--doing so provides optimal grooming results.
3. After observing the rotating action of the spin groomer, you may desire more or less aggressive grooming action. If this is the case, follow the directions provided in the next procedure for fine tuning the spin groomer operation.

Fine Tuning Spin Groomer Penetration

1. **To achieve more aggressive grooming (e.g. for hardened, compact surfaces), shorten the lower righthand linkage.** You may also want to shift the point of greatest penetration towards the "9 o'clock" position when grooming very hard, compact surfaces. *Shortening the top lift arm* of the three-point hitch will move the grooming ring's deepest penetration toward the "9 o'clock" position (refer to Figure 3A).
2. **To reduce the grooming action (e.g. for non-compacted, lightly textured surfaces), lengthen the lower righthand linkage.**

NOTE: Various conditions affect the operation of the spin groomer, including direction of travel and pitch (tilt) of the grooming ring. In some cases it may be necessary to "experiment" with these and other variables to achieve the desired grooming action.

Operating the Rake Attachment



CAUTION: When operating the rake attachment with a tractor (i.e. by itself, not with the spin groomer), be careful to make wide sweeping turns. Turning too sharply may cause the rake to swing erratically and suddenly, which may result in property/equipment damage and/or personal injury.

The angle of the rake can be adjusted, as needed, by lifting and re-positioning the spring-loaded lever at the base of the rake arm assembly. To increase the angle of the rake relative to the ground, adjust the lever toward the rear of the rake.

SECTION 4: MAINTENANCE

Guidelines for Regular Maintenance

Spin Groomer Maintenance

The only moving part on the spin groomer is the hub. The **bearings in the hub** are packed with grease at the factory and should remain in good functional operation for the life of the unit.

Periodically inspect the tines for looseness or damage. Tighten and/or replace as needed. When spin groomer is used heavily, inspect tines at least once a month.

To replace tines:

- Refer to the **Spin Groomer Parts Detail** drawing in Appendix A at the back of this manual.
- Remove the stop nut and bolt holding the tine in the bracket.
- Open the bracket to remove the damaged tine. You may need to tap lightly on the tine with a hammer to loosen it from the bracket.
- Install the new tine in the bracket. Re-install the bolt and stop nut to tighten the bracket around the tine.

APPENDIX A: PARTS REFERENCE

The following information is provided for your reference in understanding how the spin groomer is assembled and how spare parts can be identified and ordered properly.

General Spin Groomer Specifications

<u>Spin Groomer Model</u>	<u>Weight</u>	<u>Crated Shipping Wt.</u>	<u>Required Tractor HP</u>
5 ft.	210 lbs.	380 lbs.	20
6 ft.	240 lbs.	445 lbs.	25
7 ft.	280 lbs.	520 lbs.	30
<hr/>			
Rake	88 lbs.	92 lbs. (total for 2 boxes)	5**

***(when rake is used by itself)*

IMPORTANT NOTE: The **spin groomer width** should be at least *one foot wider* than the width of the rear tractor tires.

Ordering Information

When ordering replacement parts, please provide the following information to your local Millcreek dealer:

- Model and Serial Number of the unit
- Part Number and Description as it appears on the following drawings/parts lists

Spin Groomer Component Parts Detail

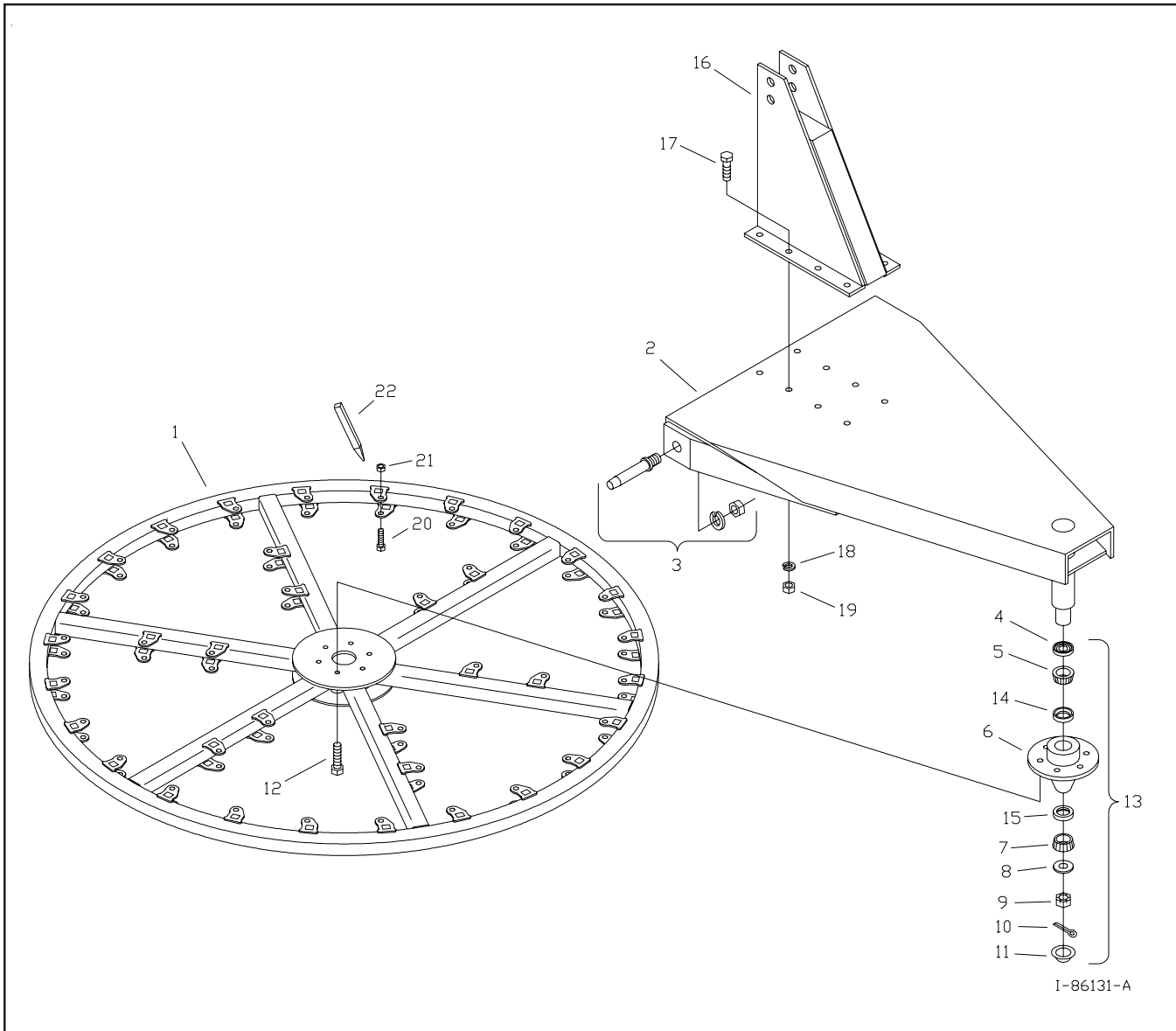

Figure A1 - Spin Groomer Parts Detail

Spin Groomer Parts Detail (continued)

<u>Item #</u>	<u>Millcreek Part #</u>	<u>Qty.</u>	<u>Component Description</u>
1	288174	1	5 ft Grooming Ring (includes items 20-22)
	288173	1	6 ft Grooming Ring
	288175	1	7 ft Grooming Ring
2	288114	1	Hitch for 5 ft. and 6 ft. Spin Groomers
	288116	1	Hitch for 7 ft. Spin Groomer
3	215193	2	Category 0, 3-point pin (.625 diameter) optional
	215117	2	Category 1, 3-point pin (.875 diameter) standard
4	215350	1	Grease Seal
5	215351	1	Inner Bearing Cone
6	215352	1	Hub (includes items 14-15)
7	215203	1	Outer Bearing Cone
8	34216	1	Washer
9	215168	1	Spindle Nut
10	34347	1	Cotter Pin
11	215161	1	Dust Cap
12	215222	6	Lug Bolt
13	215354	1	Complete Hub (includes items 4-11)
14	215353	1	Inner Bearing Cup
15	215277	1	Outer Bearing Cup
16	288135	1	3-point Mast
17	34239	8	1/2 x 1 Bolt
18	34035	8	1/2 Lock Washer
19	34034	8	1/2 Nut

<u>Item #</u>	<u>Millcreek Part #</u>	<u>Quantities</u>			<u>Description</u>
		<u>5'</u>	<u>6'</u>	<u>7'</u>	
20	34271	36	36	48	1/2 x 2-1/2 Bolt
21	34211	36	36	48	1/2 Nylon Stop Nut
22	215231	36	36	48	8" Tine

Rake Attachment Component Parts Detail

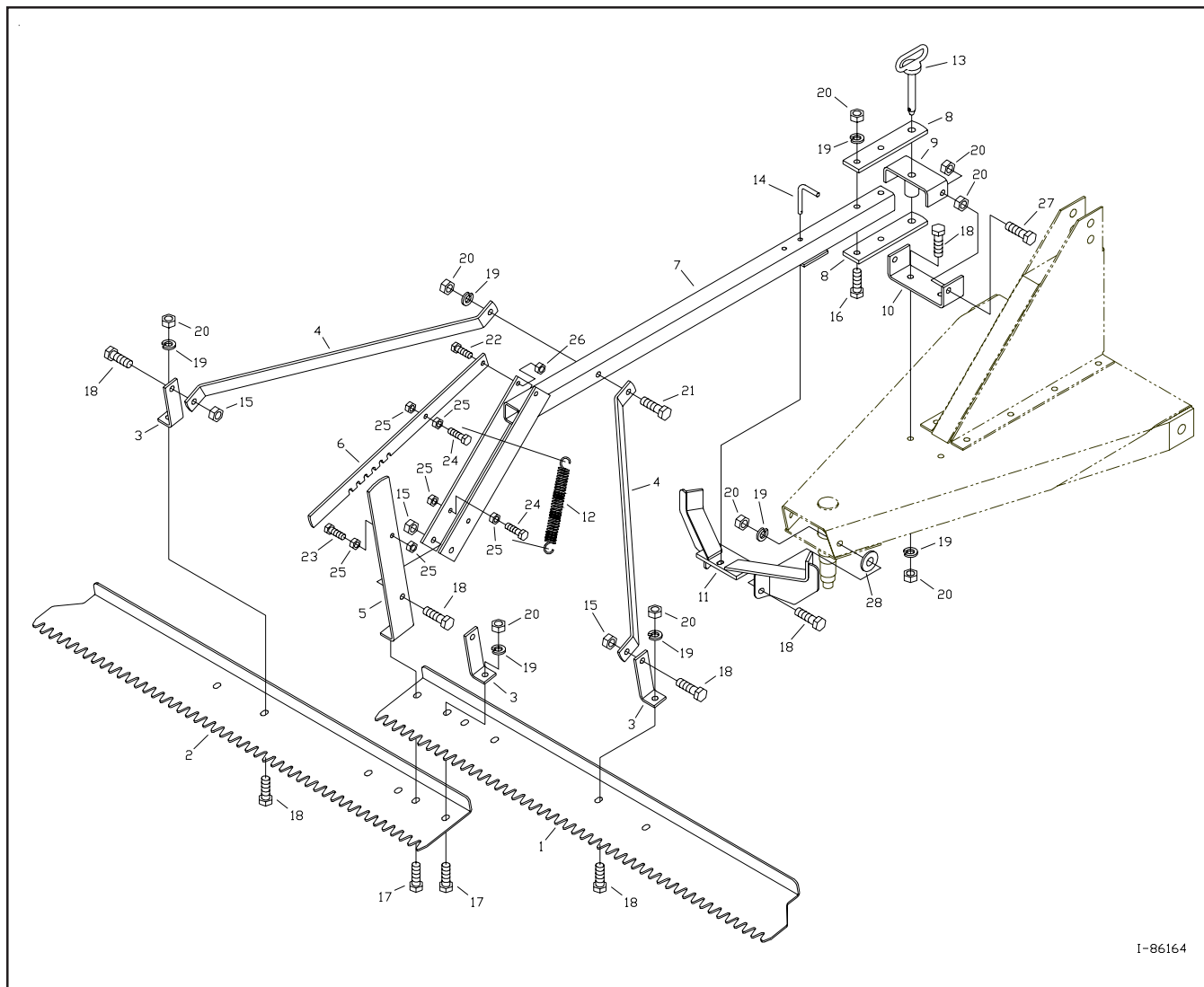

I-86164

Figure A2 - Rake Attachment Parts Detail

Rake Attachment Parts Detail (continued)

<u>Item #</u>	<u>Millcreek Part #</u>	<u>Qty.</u>	<u>Component Description</u>
1	288170	1	Right-side Rake
2	288169	1	Left-side Rake
3	288161	3	Pivot Bracket
4	288152	2	Hitch Brace
5	288153	1	Pivot Bracket Adjustment
6	288154	1	Adjustment Lever
7	288155	1	Arm
8	288145	2	Hitch Clevis
9	288140	1	Pivot Bracket
10	288147	1	Mounting Bracket
11	288166	1	Side Stop
12	220105	1	Spring
13	220156	1	Hitch Pin (5/8 Dia.)
14	220165	1	3/8 x 4 Bent Pin
15	34211	4	1/2 Lock Nut
16	34268	2	1/2 x 3-1/2 Bolt
17	34226	2	1/2 x 1-1/2 Bolt
18	34311	10	1/2 x 1-1/4 Bolt
19	34035	11	1/2 Lock Washer
20	34034	15	1/2 Nut
21	34230	1	1/2 x 3 Bolt
22	34199	1	3/8 x 1 Bolt
23	34224	1	3/8 x 1-1/4 Bolt
24	34255	2	3/8 x 1-1/2 Bolt
25	34087	6	3/8 Nut
26	34220	1	3/8 Lock Nut
27	34254	2	1/2 x 2 Bolt
28	34094	2	1/2 Washer (if needed)

